

KENWOOD **kMix**

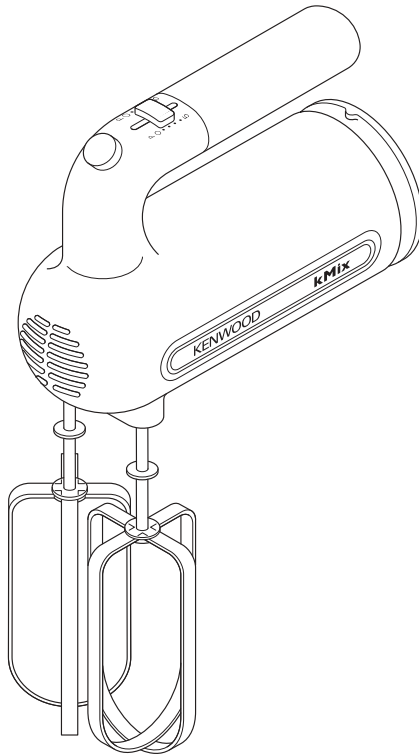

HM790 series

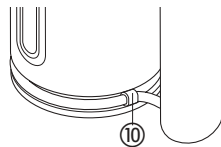
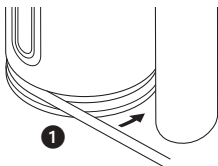
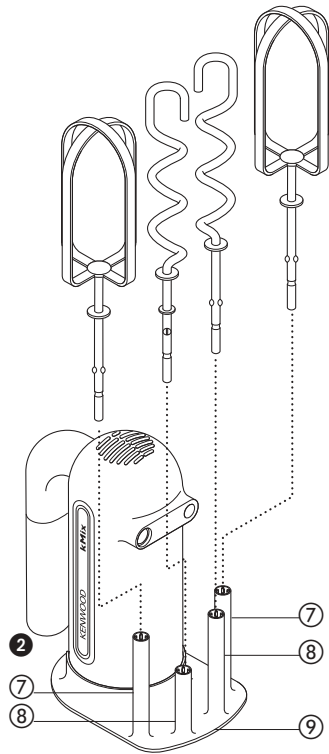
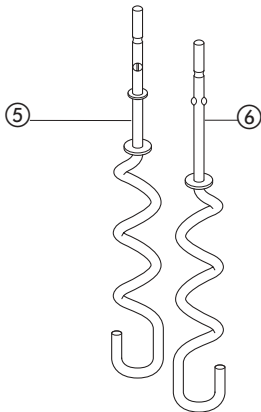
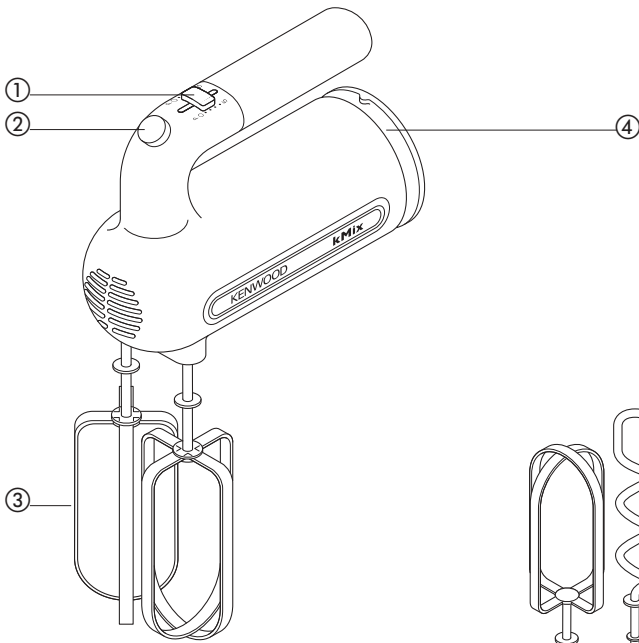

before using your Kenwood appliance

- Read these instructions carefully and retain for future reference.
- Remove all packaging and any labels.

safety

- Ensure the cord is fully unwound from the cord wrap before using the handmixer.
- Never put the handmixer body in water or let the cord or plug get wet.
- Keep fingers, hair, clothing and utensils away from moving parts.
- Never let the cord touch hot surfaces or hang down where a child could grab it.
- Never use a damaged handmixer. Get it checked or repaired: see 'service and customer care'.
- Never use an unauthorised attachment.
- Always unplug the appliance when not in use, before fitting or removing parts or before cleaning.
- This appliance is not intended for use by persons (including children) with reduced physical, sensory or mental capabilities, or lack of experience and knowledge, unless they have been given supervision or instruction concerning use of the appliance by a person responsible for their safety.
- Children should be supervised to ensure that they do not play with the appliance.
- Only use the appliance for its intended domestic use. Kenwood will not accept any liability if the appliance is subject to improper use, or failure to comply with these instructions.

before plugging in

- Make sure your electricity supply is the same as the one shown on the underside of your handmixer.

Important – UK only

- The wires in the cord are coloured as follows: Blue = Neutral, Brown = Live.
- The appliance must be protected by a 5A approved (BS1362) fuse.

Note:

- For non-rewireable plugs the fuse cover **MUST** be refitted when replacing the fuse. If the fuse cover is lost then the plug must not be used until a replacement can be obtained. The correct fuse cover is identified by colour and a replacement may be obtained from your Kenwood Authorised Repairer (see Service).

- If a non-rewireable plug is cut off it must be **DESTROYED IMMEDIATELY**. An electric shock hazard may arise if an unwanted non-rewireable plug is inadvertently inserted into a 13A socket outlet.
- This handmixer complies with European Economic Community Directive 89/336/EEC.

before using your handmixer for the first time

- Wash the parts (see 'cleaning').

key

- ① speed switch
- ② tool release button
- ③ beaters
- ④ cord wrap
- ⑤ kneader with additional collar
- ⑥ kneader without additional collar
- ⑦ beater storage pillars
- ⑧ kneader storage pillars
- ⑨ worktop storage unit
- ⑩ cord clip

to use your handmixer

- 1 Unwrap the cord from the cord wrap and make sure the speed switch is in the off position by lining up the O symbol on the handmixer body with the dot on the side of the speed switch. Insert the beaters or kneaders – turn and push until a positive click is felt. The tabs on the tool shafts need to line up with the outlet holes.
Important: The kneader with the additional collar will only fit into the larger outlet hole.
- 2 Plug in.
- 3 With the ingredients in a suitably sized bowl, place the beaters/kneaders into the bowl.
- 4 Pull the speed switch backwards to reach the desired speed (the first dot on the handmixer body is slow and speed 5 is fast). Line up the dot on the side of the speed switch with the corresponding speed.
 - As the mixture thickens, increase the speed.
 - If the machine labours increase the speed.
 - Move the speed switch forwards to the pulse position (P) to operate the motor as required. The motor will operate for as long as the pulse is held in position.
- 5 When the mixture has reached the desired consistency, return the speed switch to the off position and then lift the beaters/kneaders out of the bowl.

6 To remove the tools, make sure the speed switch is in the off position and unplug the handmixer. Press the tool release button. Hold onto the tool shafts when ejecting the tools.

Important:

- When making bread dough we recommend that the dough load does not exceed 400g flour.
- With heavy mixtures, such as dough, don't use your handmixer for longer than 3 minutes in any 5 minute period as the protection device might operate. Switch it off as soon as you've got the right consistency.
- To protect your handmixer it is fitted with a protection device which will stop the handmixer operating if overloaded. If this happens, switch off, unplug, wait a couple of minutes and then plug back into the power supply.

Recommended speeds for beaters

Please note that these are recommendations only and the speed you select may depend upon the bowl size, quantities, the ingredients you are mixing and personal preference.

Food type	Recommended speeds
Egg whites	Gradually increase the speed to 5
Cream	1 - 2
Whisked sponge	Gradually increase the speed to 3
1 stage sponge cake	1 – 3
Batter	1
Rubbing fat into flour Adding water to combine pastry ingredients	1 1

cleaning

- Always switch off, unplug and remove the beaters or kneaders before cleaning.
- Never put the handmixer body in water or let the cord or plug get wet.
- Never use abrasives to clean parts.

beaters, kneaders

- Wash by hand or in your dishwasher, then dry.

handmixer body and worktop storage unit

- Wipe with a dry to slightly damp cloth then dry.

storage

- 1 Wrap the cord around the base of the handmixer ❶ and clip the cord together using the cord clip.
- 2 Place the handmixer on its end into the worktop storage unit, ensuring the plug and handle are facing away from the storage pillars ❷.
- 3 Store the beaters in the two outside beater storage pillars.
- 4 Store the kneader without additional collar in the taller of the kneader storage pillars.
- 5 Store the kneader with additional collar in the shorter of the kneader storage pillars.

service and customer care

- If the cord is damaged it must, for safety reasons, be replaced by KENWOOD or an authorised KENWOOD repairer.

UK

If you need help with:

- using your handmixer or
 - servicing or repairs (in or out of guarantee)
- ☎ call Kenwood customer care on **023 9239 2333**.

Have your model number ready - it's on the underside of your handmixer.

- **spares and attachments**

☎ call 0870 2413653.

other countries

- Contact the shop where you bought your handmixer.

guarantee (UK only)

If your handmixer goes wrong within one year from the date you bought it, we will repair or replace it free of charge provided:

- you have not misused, neglected or damaged it;
- it has not been modified (unless by Kenwood);
- it is not second-hand;
- it has not been used commercially;
- you have not fitted a plug incorrectly; and
- **you supply your receipt to show when you bought it.**

This guarantee does not affect your statutory rights.

Recipe

white bread dough

400g/14 oz strong plain flour
10ml/2 tsp dried yeast (the type that requires reconstituting)
5ml/1 tsp sugar
5ml/1 tsp salt
13g/½ oz lard
230ml/8 fl.oz. warm water

The correct water temperature should be 43°C and can be achieved by mixing one third boiling water with two thirds cold.

Place the dried yeast with the sugar and water in a suitably sized mixing bowl (you may find a smaller bowl makes the operation easier) and leave to froth. Add the remaining ingredients. Fit the kneaders to the handmixer then combine the ingredients together on a low speed until the flour is incorporated, then increase the speed and knead until the dough is smooth and elastic for approximately 1 minute 30 seconds. Leave the dough to rise in a warm place for 45-60 minutes.

Re-knead the dough on speed 5 for 30 seconds keeping the kneaders in the mix.

Shape the dough into a loaf or rolls and place on greased baking trays. Then leave somewhere warm until it has doubled in size.

Bake at 230°C/450°F/Gas mark 8 for 20-25 minutes (for a loaf) or 10-15 minutes (for rolls). When ready the bread should sound hollow when tapped on the base.



Kenwood Limited, New Lane, Havant, Hampshire PO9 2NH, UK
www.kenwoodworld.com

18275/2